

**Integration of a projector in the ceiling, a cabinet or a table, so the projector is out of sight and is less audible?**

This idea can be realized with the Audipack Mirror-Kits. A practical and durable solution for the integration of a projector in a board room, home cinema, auditorium or conference hall. The projector is fixed permanently above the ceiling, resulting in a more silent presentation and invisibility of the projector.

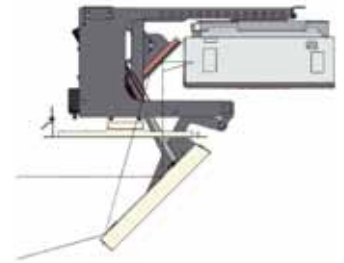

The minimized dimensions of the mirror panel do not distract and leave the attention with the projected image.



Audipack Mirror-Kits are available in various standard dimensions and versions. The Mirror-Kits are available in dynamic (motorized) and static (non-motorized) versions. Mirror-Kits are suited to dynamic installations, for example on board of yachts. All Mirror-Kits are easy to install and to adjust, and are equipped with mirrors of high optical quality. Custom built Mirror-Kits are available on request.

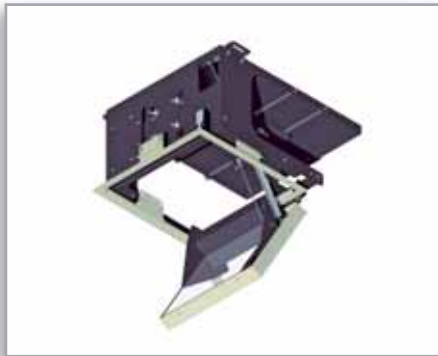

***Motorized ceiling version***

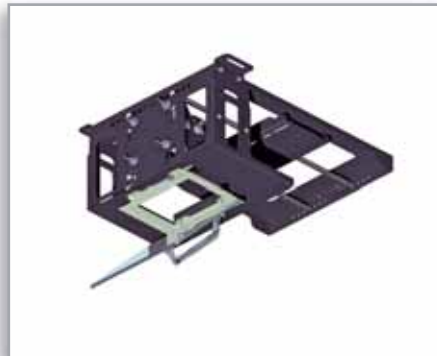

***Static ceiling versions***

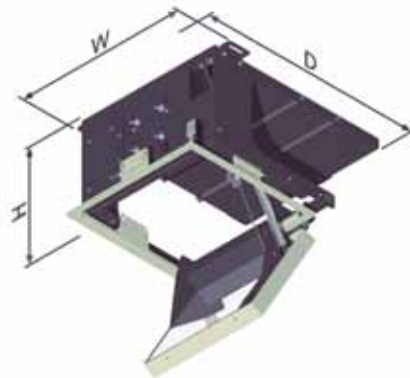

***Motorized table / cabinet version***

**Motorized ceiling Mirror-Kits**

Ref.	P0992	P1592	P1645
Model	MKT-150	MKT-200	MKT-250
Dimensions in mm*	W 587 x D 639 x H 350	W 587 x D 639 x H 400	W 587 x D 639 x H 450
Max. projector dimensions in mm	W 500 x D 600 x H 150	W 500 x D 600 x H 200	W 500 x D 600 x H 250
Max. load	15 Kg	15 Kg	15 Kg
Nett weight	31 Kg	33 Kg	35 Kg
Primary power supply	230 VAC 50-60 Hz / 24 VDC (external power supply included)		
Control	Push button (not included), IR or RF remote control (optional), system control (not included)		
Colour	Black RAL 9005		

\*Dimensions with retracted mirror

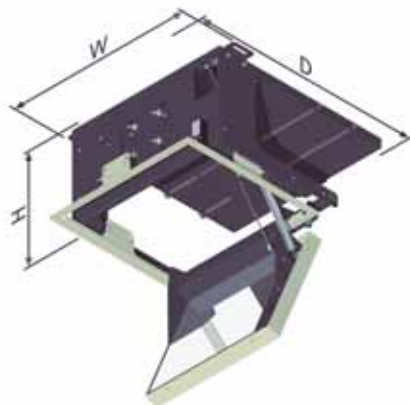
**Motorized ceiling Mirror-Kits with larger mirror for wide screen projectors**

**NEW**

Ref.	P2806	P3192	P3728
Model	MKT-150WS	MKT-200WS	MKT-265WS
Dimensions in mm*	W 620 x D 637 x H 368	W 660 x D 637 x H 418	W 735 x D 1040 x H 500
Max. projector dimensions in mm	W 500 x D 600 x H 150	W 500 x D 600 x H 200	W 600 x D 650 x H 265
Max. load	15 Kg	15 Kg	35
Nett weight	31 Kg	33 Kg	36
Primary power supply	230 VAC 50-60 Hz/ 24 VDC (external power supply included)		
Control	Push button (not included), IR or RF remote control (optional), system control (not included)		
Colour	Black RAL 9005		

\*Dimensions with retracted mirror

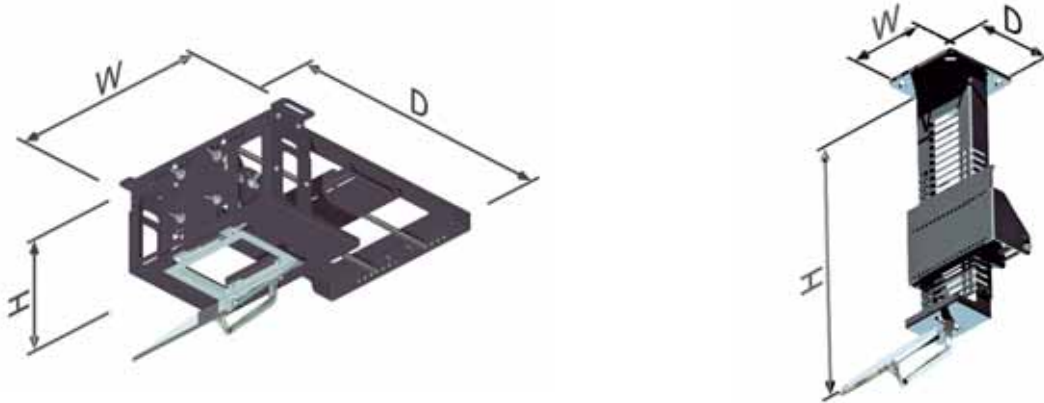
**Static ceiling Mirror-Kits**

Ref.	P2828	P1792**	P2883**
Dimensions in mm*	W 415 x D 555 x H 325	W 150 x D 150 x H 480	W 150 x D 150 x H 480
Mirror dimensions	Square W 250 x H 250	Oval W 150 x H 200	Square W 250 x H 250
Min. / Max. projector height in mm	H 95/195	H 95/200	H 95/200
Max. load	10 Kg	10 Kg	10 Kg
Nett weight	8 Kg	12 Kg	12 Kg
Colour	Black RAL 9005	Black RAL 9005	Black RAL 9005

\*\* The projector is mounted vertically and must be able to work in that position. The static Mirror-kit's are standard supplied with a ceiling finishing kit

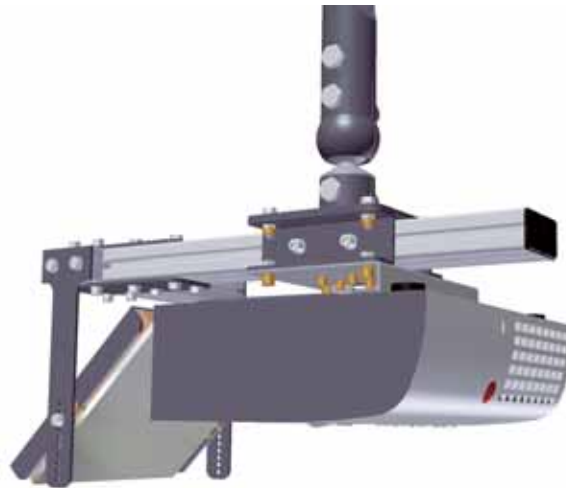
**Floor projection unit**

Ref.	P2817
Dimensions in mm*	W 465 x D 250 x H 225 - 260
Mirror dimensions in mm	W 200 x H 200
Max. load	15 Kg
Nett weight	10 Kg
Colour	Black RAL 9005 / 9006

Max. lens offset 90 mm.

To be used with 390061 and 390065, ceiling mounts (pag. 98)

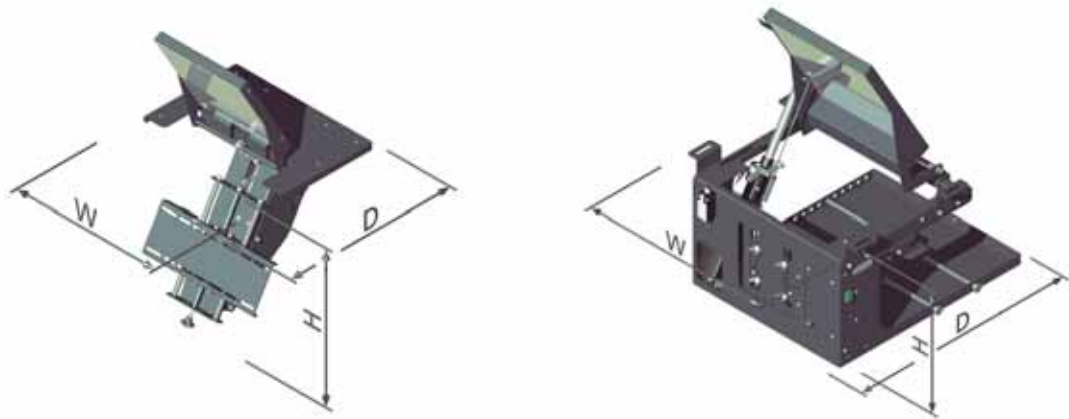
**Motorized Mirror-Kits for cabinet or table mounting**

Ref.	P3375	P1698	P1779
Model	-	MKT-150T	MKT-200T
Dimensions in mm*	W 400 x D 462 x H 399	W 562 x D 665 x H 348	W 590 x D 705 x H 398
Max. projector dimensions in mm	W 400 x D 400 x H 155	W 500 x D 600 x H 150	W 500 x D 600 x H 250
Max. load	10 Kg	15 Kg	15 Kg
Nett weight	15 Kg	31 Kg	33 Kg
Primary power supply	230 VAC 50-60 Hz / 24 VDC (external power supply included)		
Control	Push button (not included), IR or RF remote control (optional), system control (not included)		
Colour	Black RAL 9005	Black RAL 9005	Black RAL 9005

\*Dimensions with retracted mirror

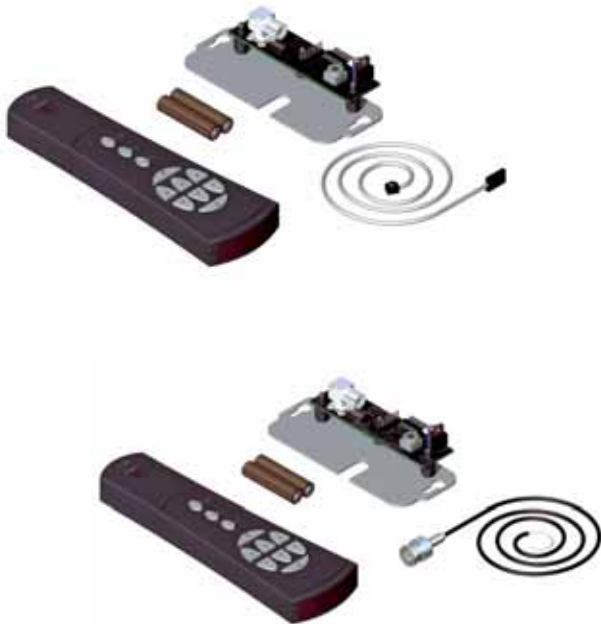
**Options**

Ref.	260214	260215
Type	Internal IR remote set	Internal RF remote set

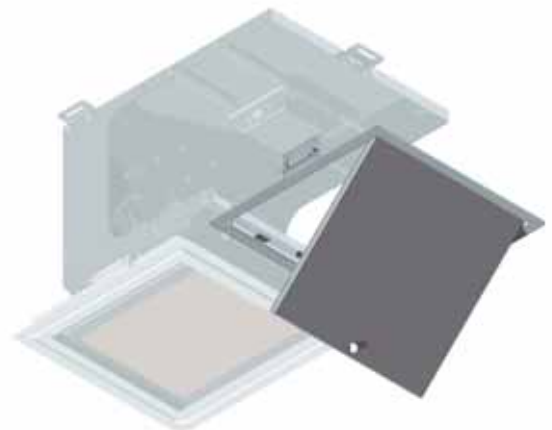
**Option**

Ref.	P1913
Type	Acces hatch Internal hatch dimensions 430 x 430 mm

